

HI-SCAN™ 9075

HEIMANN X-RAY TECHNOLOGY

New: 160 kV X-ray source – typical steel penetration 30 mm



Feature Highlights

- **Ideal method of inspecting oversized and bulky freight**
- **Ease of handling heavy goods via low conveyor belt**
- **HiTraX technology employing real-time image processing**
- **HI-MAT^{Plus} : allows improved material classification**
- **IMS: image data management (optional)**

HI-SCAN 9075 is a state-of-the-art X-ray inspection unit for the scanning of objects up to a size of 90 cm x 76 cm (w x h). Due to its design the imaging system is perfectly suited to the scanning of bulky objects, oversized baggage and freight. Heavy objects can be easily placed on the conveyor belt which is installed at a height of only 35 cm above the ground.

The low installation height of the HI-SCAN 9075 conveyor system facilitates the connection of supplementary feed- and/or discharge conveyor systems for heavy freight. The HI-SCAN 9075 is also available as mobile unit and as such is well-tried by airports, customs facilities and haulage companies.

State-of-the-art HiTraX technology, efficient online image analysis methods as well as an operator interface ergonomically designed to be adapted to the installation conditions make the HISCAN 9075 an ultramodern and efficient instrument for security checks in sensitive areas.

HI-SCAN 9075 - the security concept for dealing with oversized baggage and bulky objects.

Technical Data **HI-SCAN 9075**

General Specifications

Tunnel dimensions	910 (W) x 770 (H) [mm] • 35.8" (W) x 30.3" (H)
Max. object size	900 (W) x 760 (H) [mm] • 35.4" (W) x 29.9" (H)
Conveyor height ¹⁾	approx. 350 mm (13.7")
Conveyor speed (adjustable with frequency converter)	typical 0,25 [m/s]
max. conveyor load even distributed over the whole conveyor	150 kg (331 lbs)
Resolution (wire detectability)	standard: 36 AWG (0.13 mm) • typical: 38 AWG (0.1 mm)
Penetration (steel) ³⁾	standard: 28 mm • typical: 30 mm
X-ray dose / inspection (typical)	standard: 0.8 µSv (0.08 mrem) • with HI-MAT: 1.6 µSv (0.16 mrem)
Film safety	guaranteed up to ISO 1600 (33 DIN)
Duty cycle	100 %, no warm-up procedure required

X-ray Generator

Anode voltage • cooling	160 kV cp • hermetically sealed oil bath
Beam direction	diagonal

Image Generating System

X-ray converter	L-shaped detector line
Grey levels stored	4096
Image presentation	B/W, color
Digital video memory	1280 x 1024 / 24 bit
Image evaluation functions	VARI-MAT, 0°, OS, HIGH, electronic zoom: stepless enlargement up to 16-times
Monitor	Flat Panel LCD Monitor

Additional Features

Functions	fading-in of date/time, luggage counter, user id-number, luggage marking system (acoustic), display of operating mode, REVIEW-feature (to recall previously visible image areas), zoom overview, free programmable keys, USB 2.0 interface, stepless zoom
Options	X-ACT, HI-TIP, HI-SPOT, SEN, XPlore, IMS (image management system), Xport, Media Bay for RIDA (250 GB), CD/RW module

Installation Data

X-ray leakage	meets all applicable laws and regulations with respect to X-ray emitting devices.
CE-labelling	in compliance with guidelines 98/37/EWG, 72/23/EWG, 89/336/EWG
Sound pressure level	< 70 dB(A)
Operating- / storage temperature ⁴⁾	0° - 40°C / -20°C - +60°C
Humidity	10% - 90% (non-condensing)
Power supply ⁵⁾	standard: 230 VAC or 120 VAC +10% / -15% • 50 Hz / 60 Hz ± 3 Hz
Power consumption	approx. 1,0 kVA
Protection class system / keyboard	IP 20 / IP 43
Dimensions • Weight ⁶⁾	3040 (L) x 1290 (W) x 1840 (H) [mm] • approx. 850 kg 119.6" (L) x 50.8" (W) x 72.4" (H) • approx. 1874 lbs
Mechanical construction	steel construction with steel panels, mounted on roller castors standard color: RAL 7016 (dark gray)

¹⁾ approx. values (adjustable)

⁴⁾ extended temperature range on request

⁵⁾ different values optional

³⁾ Conds.: steel step wedge, CU wires, belt speed 0.2 m/s

⁶⁾ without control desk, keyboard, monitor(s) etc.

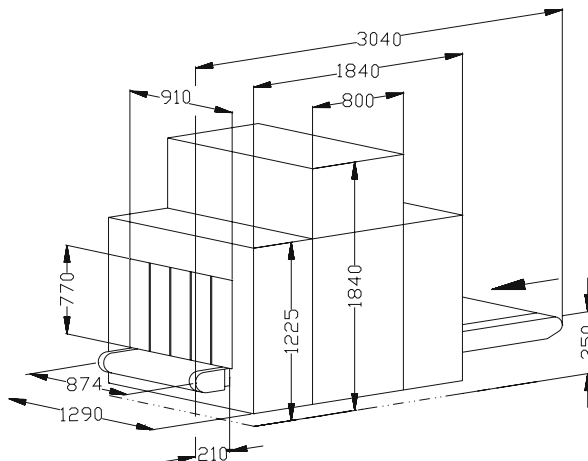

For product information, sales or service, please go to www.smithsdetection.com/locations

Smiths Heimann GmbH, Im Herzen 4, 65205 Wiesbaden, Germany
Modifications reserved. 95585661 10/10/2011 © Smiths Detection Group Ltd. - In some cases, the figures contain options
HI-SCAN is a trademark of Smiths Detection Group Ltd.

