

The attractively styled VRG provides a comfortable passage width that accommodates wheelchairs.

Designed to operate independently or in conjunction with Alvarado's waist high turnstiles, VRG gates are solidly constructed from fully welded tubular stainless steel.

All gates include a kick plate and self-closing mechanism. Single direction gates include a hydraulic dampener to minimize slamming during closure.

The standard gate without locks (VRG) may be ordered as a single or bi-directional gate.

Single direction, electric lock gates are also available (VRGX). This model comes with an electric strike lock and easily integrates with virtually any access control or identification system.

Available finishes include satin stainless steel and durable powder coat in a variety of colors.



- ***Wheelchair Accessible***
- ***Attractive Design***
- ***Single or Bi-Directional Configuration***
- ***Standard & Electric Lock Controlled Models***

Secur**MAR**

833 Shannon Drive | Crown Point, IN 46307

Phone: 219-661-8964 | Fax: 219-661-8965 | sales@securmar.com

ALVARADO

DESCRIPTION

PRODUCT NAME

VRG - waist high security gate

APPLICATIONS

Standard VRG - Often used with post & rail in facilities needing wheelchair access. Single or bi-directional.

Electric VRGX - Offers single direction access with electric lock control. Easily integrated with access control systems.

PRODUCT FEATURES - Mechanical

Materials and Operation

- Heavy gauge materials meeting appropriate ASTM standards
- Fully welded stainless steel gate arm assembly
- Latch and hinge posts are constructed of tubular steel with all welds ground smooth
- Self closing
- Slam resistant hydraulic dampener (Single direction units only)
- Gate posts secure to the floor with four anchor bolts

Finishes

- #304 stainless steel polished to a #4 satin finish
- Baked on color powder coat

PRODUCT FEATURES - Electrical

Electric

- Primary power is stepped down and rectified for low voltage 12 VDC operation
- 120 VAC input step down transformer is included

Electric Locks/Activation

- Reliable electric strike lock mechanism is used on all VRGX gates
- Capable of integrating with virtually any access control system
- Gate is activated (unlocked) when power is removed
- Gate relocks after gate arm closes and power is restored
- Standard VRGX operates in a "Fail Safe" mode with gate unlocking during loss of power

VRG(X) OPTIONS

Remote Activation - Push button or key switch provides an "unlock" signal from a remote location.

Fail Lock Electric Strike Lock - This option replaces the standard fail safe VRGX configuration, with a fail lock electric strike lock. When configured with the fail lock option, the VRGX gate remains locked during a loss of power.

WARRANTY

Alvarado's standard one-year written warranty applies to all products.

VRG(X) Dimensions

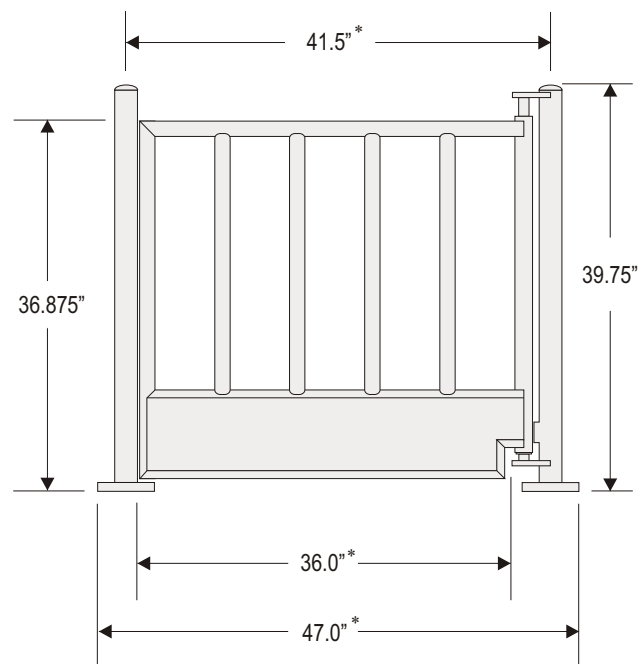

* NOTE: Dimensions may vary slightly depending on locking mechanism used.